



ROHDE & SCHWARZ

Test and Measurement
Division

Service Manual

VSWR Bridge and Power Divider

R&S FSH-Z2

10 MHz to 3 GHz

1145.5767.02

Contents

1 Performance Test	1.1
Test Instructions	1.1
Measuring Equipment and Accessories	1.1
Performance Test	1.2
Checking the directivity	1.2
Checking the Return Loss of the TEST Port.....	1.3
Performance Test Report	1.4
2 Adjustment	2.1
3 Repair	3.1
Instrument Design and Functional Description	3.1
Description of the block diagram	3.2
SWR Bridge	3.2
Power Divider.....	3.2
Spare Part Replacement	3.3
Overview of the spare parts	3.4
Opening the instrument.....	3.4
Closing the instrument	3.4
Replacing the Top/Bottom covers.....	3.5
Replacing the power cable assembly	3.6
Replacing the coax cable assembly.....	3.8
Replacing the N connector of the TEST Port.....	3.9
Replacing the N connector of the GEN OUTPUT Port	3.9
Troubleshooting	3.10
Overview of errors, causes, and possible corrective actions.....	3.10
Troubleshooting problems	3.10

4 Documents4.1

Shipping of Instrument and Ordering of Spare Parts4.1

 Shipping of instrument4.1

 Shipping of a module4.1

 Ordering spare parts4.2

 Refurbished modules4.2

 Return of defective replaced modules4.2

Spare Parts4.3

1 Performance Test

Test Instructions

- Values specified in the following sections are not guaranteed. Only the technical specifications provided on the data sheet are binding.
- The values specified in the data sheet are the guaranteed limits.
- All non used ports are supposed to be terminated with a 50 Ohm load.
- Inputs for settings during measurements are shown as following:
 - [<KEY>] Press a key on the front panel, eg **[SPAN]**.
 - [<SOFTKEY>] Press a softkey, e.g. **[MARKER -> PEAK]**.
 - [<nn unit>] Enter a value and terminate by entering the unit, e.g. **[12 kHz]**.
 Successive entries are separated by [:], e.g. **[BW : MANUAL RES BW : 3 kHz]**.

Measuring Equipment and Accessories

Item	Type of equipment	Specifications recommended	Equipment recommended	R&S order no.	Use
1	Spectrum Analyzer with TG output	Frequency: 10 MHz to 3 GHz	R&S FSH	1145.5850.13	Directivity InsertionLoss ReturnLoss
2	SWR Bridge	Directivity > 40 dB , RL testport > 20 dB	R&S ZRB 2	0373.9017.53	ReturnLoss
3	Short Circuit Termination	10 MHz to 3 GHz N-type male	R&S FSH-Z30	1145.5773.02	Directivity ReturnLoss
4	50-Ω termination N-male	10 MHz to 3 GHz Return loss ≤ -35 dB	R&S FSH-Z31	1145.5780.02	Directivity InsertionLoss ReturnLoss
5	Precision Adapter	N-male to N-male	Huber&Suhner: 32 N-50-0-51		ReturnLoss
6	50-Ω termination N-female (2x)	10 MHz to 3 GHz	Pasternack: PE6032		ReturnLoss
7	Adapter	N-male to N-male	Huber&Suhner: 32 N-50-0-1		ReturnLoss
8	Cable	Flexible cable RG213/U with N-male connector on both sides. L=approx 30 cm	Pasternack: PE3496-12		InsertionLoss ReturnLoss

Performance Test

Checking the directivity

- Test equipment:
- Spectrum Analyzer (refer to section "Measurement Equipment and Accessories", item 1)
 - 50 Ohm termination (refer to section "Measurement Equipment and Accessories", item 4)
 - Short Circuit termination (refer to section "Measurement Equipment and Accessories", item 3)
- Test setup:
- Mount the R&S FSH-Z2 on to the spectrum analyzer (item 1).
- Spectrum Analyzer settings:
- [**PRESET**]
 - [**FREQ**]
 - [START FREQ : 10 MHz]
 - [STOP FREQ : 3 GHz]
 - [**BW** : MANUAL VIDEO BW : 3 kHz]
 - [**MEAS** : TRACKING GEN : MEASURE]
 - [REFLECT CAL : CONTINUE]
- Measurement:
- Connect the Short Circuit termination (item 3) to the "TEST" Port of the R&S FSH-Z2
 - Press softkey [CONTINUE] on the Spectrum Analyzer.
 - Replace the Short Circuit termination (item 3) on the "TEST" Port of the R&S FSH-Z2 with the 50 Ohm termination (item 4).
 - The curve shows the directivity (limited by returnloss of the used 50 Ohm termination, item 4).
- Hint:
- As far as the datasheet states only typical values, the test limits are some dB worse than these numbers!

Checking the Return Loss of the TEST Port

Test principle:	Measure the returnloss of the TEST port of the DUT using a Standing Wave Ratio Bridge
Test equipment:	<ul style="list-style-type: none">- Spectrum Analyzer (refer to section "Measurement Equipment and Accessories", item 1)- SWR bridge (refer to section "Measurement Equipment and Accessories", item 2)- Short circuit termination (refer to section "Measurement Equipment and Accessories", item 3)- Precision Adapter (refer to section "Measurement Equipment and Accessories", item 5)- Two 50 Ohm terminations N-female (refer to section "Measurement Equipment and Accessories", item 6)- Adapter (refer to section "Measurement Equipment and Accessories", item 7)- Cable (refer to section "Measurement Equipment and Accessories", item 8)
Test setup:	<ul style="list-style-type: none">➤ Connect TG output of the spect. Analyzer (item1) to RF input of SWR Bridge (item 2) using adapter (item 7)➤ Connect output of the SWR Bridge (item 2) to the RF input of the spect. analyzer using cable (item 8).➤ Connect the Short Circuit termination (item 3) onto the TEST Port of the SWR Bridge (item 2).
Spectrum Analyzer settings:	<ul style="list-style-type: none">- [PRESET]- [FREQ]- [START FREQ : 10 MHz]- [STOP FREQ : 3 GHz]- [BW : MANUAL VIDEO BW : 3 kHz]- [MEAS : TRACKING GEN : MEASURE]- [TRANSM CAL : CONTINUE]
Measurement:	<ul style="list-style-type: none">➤ Connect the two 50 Ohm terminations (item 6) to the ports "GEN OUTPUT" and "RF INPUT" of the R&S FSH-Z2➤ Remove Short Circuit termination (item 3) from TEST port of the SWR Bridge (item 2).➤ Connect TEST port of the DUT with the TEST port of the SWR Bridge (item 2) using an precision adapter (item 5)➤ The curve shows the return loss of the DUT.

Performance Test Report

Table 1-1 Performance Test Report

ROHDE & SCHWARZ	VSWR Bridge	Version 12 12 2003
Model (): R&S FSH-Z2		
Order number: 1145.5767.02		
Serial number:		
Date:		

Characteristic	Included in	Min. value	Actual value	Unit	Measurement uncertainty
Directivity	Page 1.2				
.01 .. 1.0 GHz		25	_____	DB	+0.5/-0.5
1.0 .. 2.7 GHz		20	_____	dB	+0.5/-0.5
2.7 .. 3.0 GHz		17	_____	dB	+0.5/-0.5
TEST Port Match	Page 1.3				
.01 .. 2.2 GHz		16	_____	dB	+0.6/-0.6
2.2 .. 3.0 GHz		16	_____	dB	+1.6/-2.1

2 Adjustment

The R&S FSH-Z2 does not have any possibilities for adjustment.

3 Repair

This chapter describes the design of the R&S FSH-Z2, simple measures for repair and troubleshooting, and, in particular, the replacement of parts.

Instrument Design and Functional Description

The following figure shows a schematic diagram of the R&S FSH-Z2.

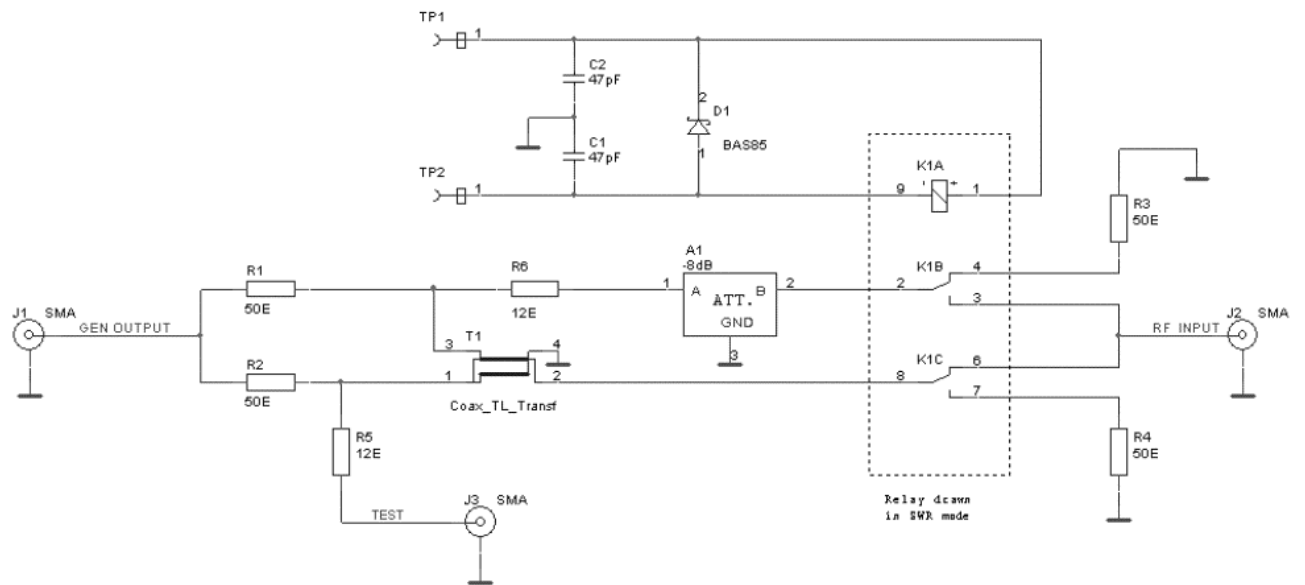

Fig. 3-1 Schematic Diagram R&S FSH-Z2

Description of the block diagram

The R&S FSH-Z2 has two states. In the first state it functions as a SWR bridge. In the second state it functions as a power divider which can be used for Distance To Fault measurements. The R&S FSH-Z2 contains a 5V relay which can be used to switch between the two states. The relay can be activated through the cable assembly ending with a 7 pol Binder connector.

SWR Bridge

This state is used for the Standing Wave Ratio measurement.

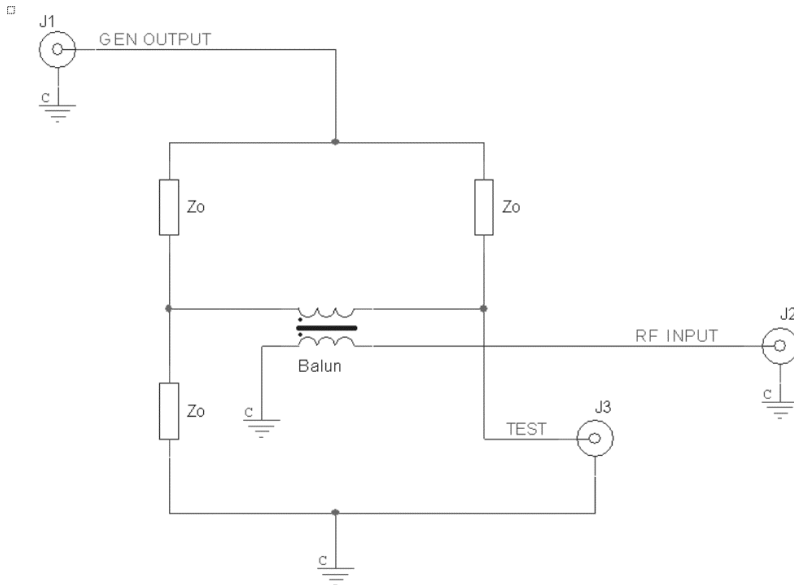

Fig. 3-2 Principle Diagram: Circuit in SWR Bridge state

Power Divider

This state is used for the Distance To Fault measurement.

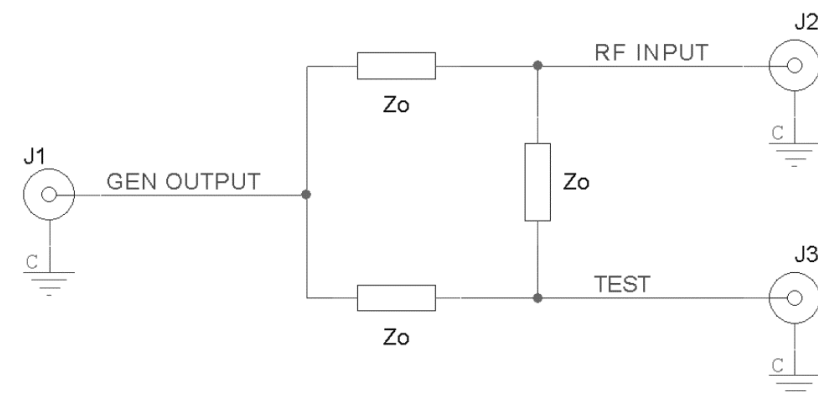

Fig. 3-3 Principle Diagram: Circuit in Power Divider state

Spare Part Replacement

This section describes the service concept and contains the spare parts list and the basic documents for the R&S FSH-Z2 instrument.

Note: The numbers indicated in brackets refer to items in the mechanical exploded drawings.

Note: The words “left” and “right” in the manual always refer to the front view of the instrument.



Caution!

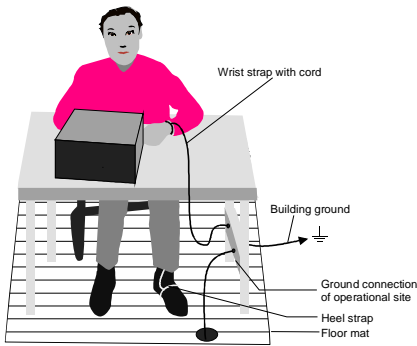

- Please pay close attention to the safety instructions in the front section of this manual.
- Safeguard the replacement site against electrostatic discharge to prevent damage to electronic components.
- The following two methods of ESD protection can be used together or separately:
 - Wrist strap with cord to ground connection
 - Conductive floor mat and heel strap combination

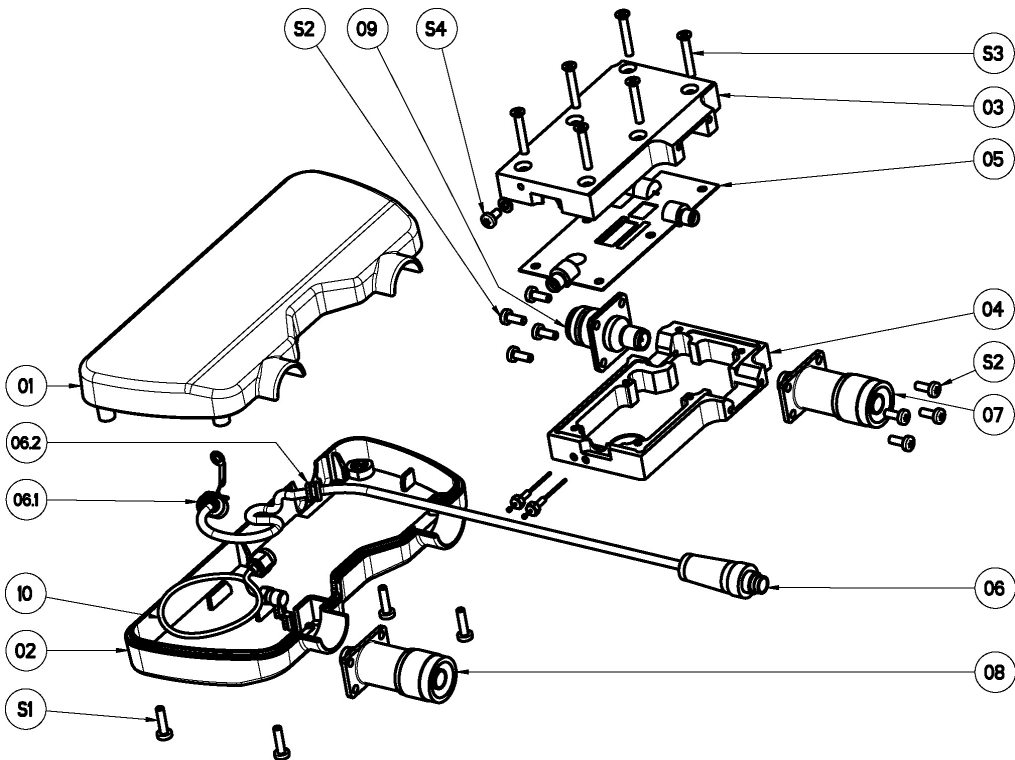

Fig. 3-4 Exploded View

Overview of the spare parts

Table 3-1 List of spare parts and order numbers

Reference	Part	R&S Order Number
01/02/S1	Plastic Top/Bottom Cover	1157.3506.00
06	Power Cable Assembly (Binder connector)	1157.3512.00
07/10	Coax Cable Assembly	1157.3529.00
09/S2	N-connector for TEST Port	1157.3535.00
07/S2	N-connector for GEN OUTPUT Port	1157.3541.00
03/04/07/09/ S2/S3/S4	SWR-DTF Unit	1157.3558.00

Note: The references can be found in the exploded drawing on the previous page.

Opening the instrument

(See exploded drawing for related numbers.)

- Loosen the four screws (S1).
- Turn the instrument so that the bottom with type plate touches the table.
- Remove the top cover (item 01).

Closing the instrument

- Place the top cover (item 01).
- Turn the instrument so that the top cover touches the table.
- Fasten the four screws (S1).

Replacing the Top/Bottom covers

Housing parts:

- 01: Top cover
- 02: Bottom cover

Notes: *When replacing the bottom cover, the existing type plate must be placed on the new bottom cover, or the old series number must be written on the new type plate.*

- Open the instrument as described earlier.
- Replace the specific cover.
- Close the instrument as described earlier.

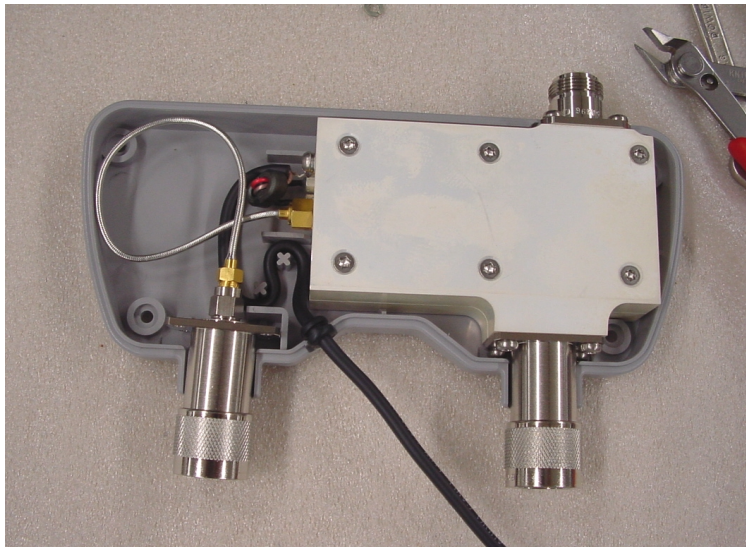

Fig. 3-5 Location of the power cable assy and the coax cable assy in the bottom cover.

Replacing the power cable assembly

(See exploded view for references).

- Open the instrument as described earlier.
- Remove the defective power cable assembly.
 - Loosen screw (S4)
 - Remove black shrink sleeve and desolder the two wires from the two pins.
 - Remove the ferrite bead (item 06.1) and the black wire tule (item 06.2)

➤



Fig. 3-6 Take the new power cable assy and slide the black wire tule (item 06.2) to 14.5 cm

➤

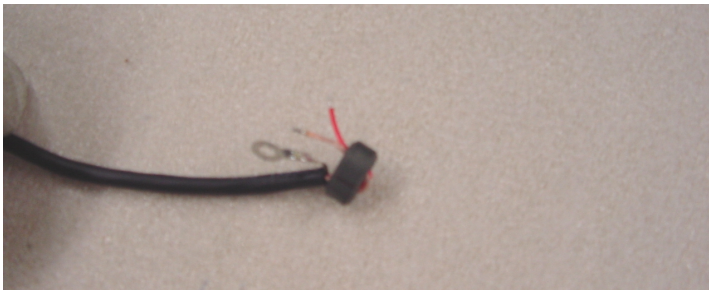

Fig. 3-7 Put the wires through the ferrite bead (item 06.1).

➤

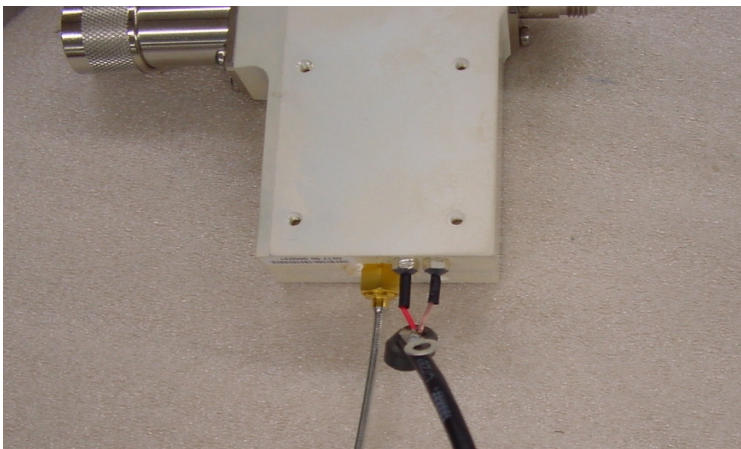

Fig. 3-8 Solder the wires to the pins.

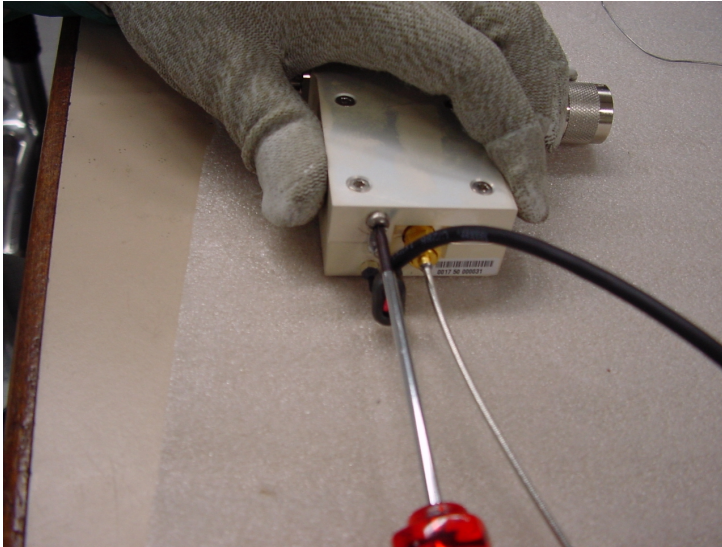

Fig. 3-9 Mount the grounding wire with soldertag to the unit using screw (S4)

- Close the instrument as described earlier.

Replacing the coax cable assembly

(See exploded view for references).

- Open the instrument as described earlier.

➤



Fig. 3-10 Connect the coax assy (item 10) to the N-SMA connector (item 07) using a torque wrench

➤

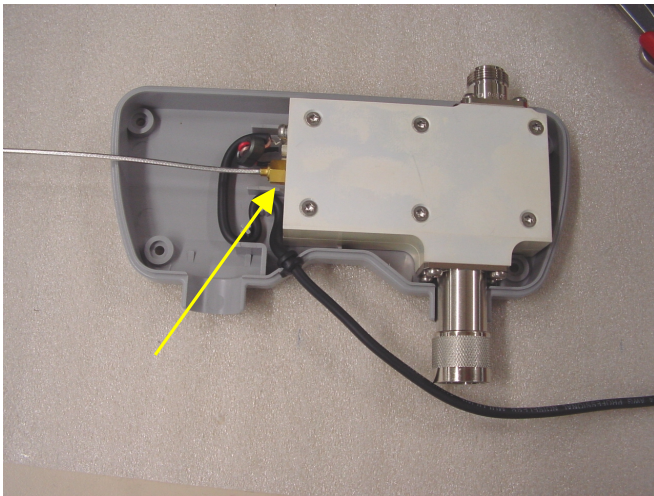

Fig. 3-11 Connect the coax assy (item 10) to the unit using a torque wrench.

- Bend the coax assy as shown in Fig. 3-5
- Close the instrument as described earlier.

Replacing the N connector of the TEST Port

- Open the instrument as described earlier.
- Loosen the 6 screws (S3) from the metal top cover.
- Loosen the top two screws (S2) from both N-connectors.
- Remove the metal top cover (item 03).
- Remove the bottom two screws (S2) from the N-connector of the TEST port.
- Remove the faulty N-connector of the TEST port.
- Mount the new connector (item 09) by first screwing it onto the SMA connector of the PCB.
- Fasten the N-connector with 2 screws (S2) into the metal bottom cover
- Mount the metal top cover (item 03).
- Fasten the other four screws (S2) from the N connectors.
- Fasten the 6 screws (S3) of the metal top cover.
- Close the instrument as described earlier.

Replacing the N connector of the GEN OUTPUT Port

- Open the instrument as described earlier.
- Loosen the 6 screws (S3) from the metal top cover.
- Loosen the top 2 screws (S2) from both N-connectors.
- Remove the metal top cover (item 03).
- Remove the bottom two screws (S2) from the N-connector of the GEN OUTPUT port.
- Remove the faulty N-connector of the GEN OUTPUT port.
- Mount the new connector (item 07) by first screwing it onto the SMA connector of the PCB.
- Fasten the N-connector with 2 screws (S2) into the metal bottom cover
- Mount the metal top cover (item 03).
- Fasten the other four screws (S2) from the N connectors.
- Fasten the 6 screws (S3) of the metal top cover.
- Close the instrument as described earlier.

Troubleshooting

Malfunctions can have simple causes but can also be due to faulty components or modules. These troubleshooting instructions can be used to locate causes of error down to spare parts level and to return the instrument to operability by replacing parts.

Note: *When problems occur, first check whether any connections (cables, plug-in connections of boards, etc) are damaged or incorrectly connected.*

Overview of errors, causes, and possible corrective actions

This section lists various errors and the suggested corrective action.

Troubleshooting problems

- **Error: Directivity of R&S FSH-Z2 shows a resonance bump at frequencies higher than 2 GHz.**

Troubleshooting procedure	Possible cause of error and further steps
Check the N connector of the TEST Port	The N connector of the TEST Port is soiled. <i>Clean or replace this female N connector.</i>

- **Error:**

Troubleshooting procedure	Possible cause of error and further steps
Check ↓	Cause of error. <i>Repair Action.</i>
Next Check	<i>Repair Action.</i>

4 Documents

This chapter provides information on how to order spare parts, and it also contains the spare parts list.

Shipping of Instrument and Ordering of Spare Parts

Please contact your Rohde & Schwarz support center or our spare parts express service if you need to request service, repair your equipment, or order spare parts and modules.

The list of Rohde & Schwarz representatives and the address of our spare parts express service are provided in the front section of this service manual.

You will need to provide the following information in order for us to respond to your inquiries quickly and accurately and to determine whether the warranty for your instrument is still valid:

- Instrument model
- Serial number
- Detailed error description in case of repair
- Contact partner for checkbacks

Shipping of instrument

When shipping the instrument, be sure to provide sufficient mechanical and anti-static protection:

- Repack the instrument as it was originally packed. The antistatic packing foil prevents unintentional electrostatic charging from occurring.
- If you do not use the original packaging, include sufficient padding to prevent the instrument from slipping inside the package. Wrap antistatic packing foil around the instrument to protect it from electrostatic charging.

Shipping of a module

When shipping a module, be sure to provide sufficient mechanical and antistatic protection:

- Ship the module in a sturdy, padded box.
- Wrap the board in antistatic foil.
If the packaging is antistatic but not conductive, additional conductive packaging is required. The additional packaging is not required if the enclosed packaging is conductive.

Ordering spare parts

To deliver replacement parts promptly and correctly, we need the following information:

- R&S order number (refer to the spare part lists in this chapter)
- Designation
- Number of units
- Instrument type for the replacement part
- Contact person for possible questions

The R&S order number to be used when ordering replacement parts and modules as well as power cables can be found further below.

Refurbished modules

- Refurbished modules are an economical alternative to original modules. It should be kept in mind that refurbished modules are not new, but repaired and fully tested parts. They may have signs of use but they are electrically and mechanically equivalent to new modules.
- To find out which refurbished modules are available, please contact your Rohde & Schwarz representative (or the central service division at Rohde & Schwarz in Munich).

Return of defective replaced modules

- Defective modules of the replacement program that can be repaired may be returned within **3 months** after delivery of the replaced module. A repurchasing value is credited.
- Excluded are parts that cannot be repaired, e.g. PCBs that are burned, broken or damaged by repair attempts, incomplete modules, or parts that have endured heavy mechanical damage.
- Defective parts must be sent back with an **accompanying document of returned items** containing the following information:
 - R&S order number, serial number and designation of the removed part
 - **Precise** description of the error
 - R&S order number, serial number and designation of the instrument the part was removed from
 - Date of part removal
 - Name of the technician who exchanged the part
- A **document of returned items** is provided along with each replacement module.

Spare Parts

The R&S Order numbers necessary for ordering replacement parts and modules can be found in the spare part lists provided below.



Important Note!

When replacing a module, please pay careful attention to the safety instructions and the repair instructions provided in chapter 3 and at the beginning of this service manual.

When shipping a module, be sure to provide sufficient mechanical and antistatic protection.

List of R&S FSH-Z2 spare parts

The following table lists available spare parts together with their R&S order numbers.

Table 4-1

Reference	Part	R&S Order Number
01/02/S1	Plastic Top/Bottom Cover	1157.3506.00
06	Power Cable Assembly (Binder connector)	1157.3512.00
07/10	Coax Cable Assembly	1157.3529.00
09/S2	N-connector for TEST Port	1157.3535.00
07/S2	N-connector for GEN OUTPUT Port	1157.3541.00
03/04/07/09/ S2/S3/S4	SWR-DTF Unit	1157.3558.00

Note: *The references can be found in the exploded drawing in Chapter 3.*